

# WD1002A-WX1 (VER.1) Hard Disk/Floppy Controller Settings and Configuration

---

## WESTERN DIGITAL CORPORATION WD1002A-WX1 (VER.1)

Data Bus	8-bit
Card Size	Proprietary
Hard Drives supported	Two ST-506/412(MFM) drives
Floppy drives supported	None

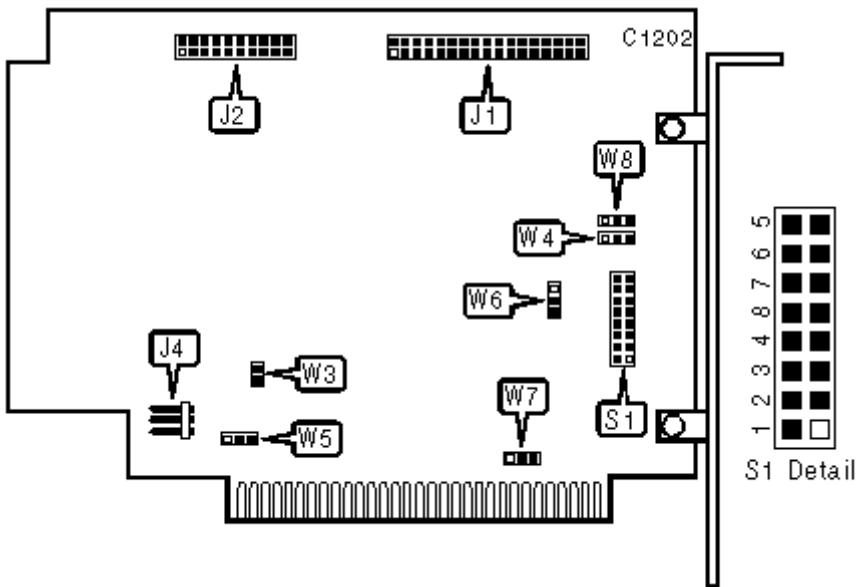

## CONNECTIONS

Function	Location	Function	Location
34-pin control cable connector-hard drive	J1	5-pin connector-DC power	J4
20-pin data cable connector-drive 0	J2		

## USER CONFIGURABLE SETTINGS

Function	Label	Position
» BIOS enabled	W3	Closed
BIOS disabled	W3	Open
» I/O port address 320h	W4	pins 2 & 3 closed
I/O port address 324h	W4	pins 1 & 2 closed
» BIOS ROM size 32K or 64K (hard-wired)	W5	pins 1 & 2 closed
BIOS ROM size 16K	W5	pins 2 & 3 closed
» 8 head hard drive with RWC supported	W6	pins 2 & 3 closed
16 head hard drive supported (head select 3)	W6	pins 1 & 2 closed
» Hard drive Interrupt is IRQ5 (hard-wired)	W7	pins 1 & 2 closed
Hard drive Interrupt is IRQ2	W7	pins 2 & 3 closed

»	Single controller setting, primary controller	W8	pins 2 & 3 closed
	Dual controller setting, secondary controller	W8	pins 1 & 2 closed
»	Factory configured - Do not alter	S1/5	Open
»	Factory configured - Do not alter	S1/6	Open
»	Factory configured - Do not alter	S1/7	Open
»	Factory configured - Do not alter	S1/8	Open

#### BIOS REVISION DRIVE TYPE TABLE

	Drive1	Drive 0				Cap.	Hds	Cyls.	WP	RWC
	#	S1/1	S1/2	S1/3	S1/4					
	0	Closed	Closed	Closed	Closed	20 MB	4	612	613	613
	1	Open	Closed	Open	Closed	10 MB	2	612	128	128
	2	Closed	Open	Closed	Open	20 MB	4	612	128	613
»	3	Open	Open	Open	Open	10 MB	4	306	0	306

Note: S1/1 and S1/2 select the setting for drive1 & S1/3 and S1/4 select the setting for drive 0

#### MISCELLANEOUS TECHNICAL NOTES

Note: This controller has a built-in low-level format program. To enter the program, run the DEBUG utility supplied with DOS and at the prompt enter: G=C800:5. Two additional jumpers may be present,

W1 & W2, and are reserved for factory use and may not be changed.

Search

[▲ Top](#)

[◀ Prev](#)

[Up](#)

[Next ▶](#)

## Topics

[Articles](#)

---

[Development](#)

---

[Books](#)

---

[Teaching](#)

---

[Photography](#)

---

[Bits and Pieces](#)

---

[TULARC](#)

---

## My Books

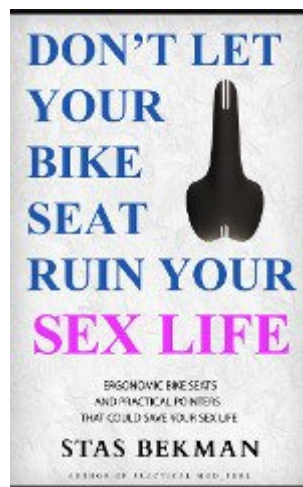
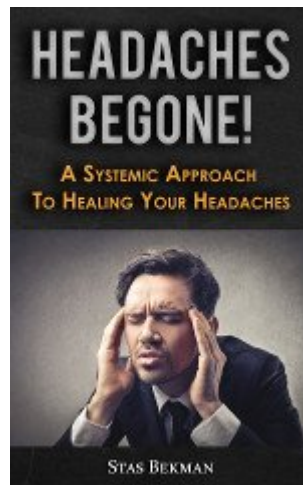

Discover

[Free Online Books](#)

---

[ [Privacy Policy](#) | [Terms of Use](#) | [About Us](#) | [Search](#) ]

© 1999-2021 [StasoSphere.com](#)